

Raven BPI Operation Manual

Raven Bluetooth Pilot Interface

Jun 30, 2009



Raven Industries, Inc

See document, RavenContactInfo.pdf, for contact info.

Copyrights

© 2009, Raven Industries, Inc. All rights reserved. No part of this manual may be copied, photocopied, reproduced, translated, or reduced to any electronic medium or machine-readable form without prior written consent from Raven Industries, Incorporated.

Printed in the United States of America

This Manual Part Number.. 016-0171-222
BPI Part Number 063-0173-005

Contents

The Raven Bluetooth Pilot Interface (BPI)	3
BPI Cables and Adapters	4
BPI LED Status Lights	5
Yellow LED - Charging	5
Green LED - AIS Data	5
Blue LED - Bluetooth	5
Red LED - Battery	5
Ship's AIS and the Raven BPI	6
USB Operation	6
Bluetooth Operation.....	7
Bluetooth Performance.....	7
Bluetooth Connection	8
Bluetooth Name.....	9
AIS Operation.....	10
Soft Shutdown	10
Low-Charge Shutdown	10
BPI Messages	11
Message Protocol.....	11
Command Messages and Related Query Messages.....	12
Set BPI Name	12
Set BPI Bluetooth Security Key	12
Set Event Messages On/Off	12
Set Number of Minutes until Soft Shutdown.....	13
Reset Command.....	13
Factory Default Command.....	13
Loopback Mode	13
Force AIS Lock Mode	14
Night mode for Status LED Lights	14
Adjust Individual LED Brightness	14
Event Messages	15
PPI State Response	15
Battery Parameters Response	15
Performance Response	15
Wire Wizard Scan Results	16
Stand-Alone Query Messages	17
Query Battery Parameters.....	17
Query Device ID	17
Query PPI State.....	18
Diagnostic Messages	19
Reset Battery Monitor	19
Reset Bluetooth Module	19
Bluetooth AT Command Mode	19
Begin a New Data Scan	19
Signal Interval	19
Update History.....	20

The Raven Bluetooth Pilot Interface (BPI)

The Raven Bluetooth Pilot Interface (BPI) is a Bluetooth wireless device that translates data from an AIS Pilot Port Interface (PPI) plug found on a ship and transmits that AIS data to a computer via a Bluetooth or USB serial data link.



Figure 1 - BPI with AIS PPI (Pilot Port Interface) Cable

The BPI has the following features:

- Rechargeable Battery allows for 20+ hours of operation on a single charge ⁽¹⁾
- LED indicators for
 - Wireless connection status – Blue LED
 - Power, including low power indication – Red LED
 - Pilot Plug data status – Green LED
 - Unit recharge status – Yellow LED
- On-Off Switch
- Wire Wizard – the BPI will auto-correct for wiring errors on the Pilot Plug.
- Auto Baud – the BPI will detect PPI signals at 9600, 19200 and 38400 baud and convert them to a standard 38400 baud output.
- USB Connector provides backup communications path for AIS data.
- Supports Night Mode which will dim the LED status lights at night.
- BPI firmware can be updated in the field with supplied software.
- 7 Pin SATA Connector to connect BPI to Pilot Plug using Raven supplied cable.
- Class I Bluetooth Wireless Data Link with range up to 100 meters open air. ⁽²⁾
- Soft Shutdown after 60 minutes with no AIS data to conserve battery life
- Low Weight: 3.6 oz
- Small Size: Dimensions: 4" x 2" x 1"

(1) Actual battery life will depend on many factors, including temperature, range and BPI age.

(2) See the notes under the Operation section for restrictions on Bluetooth transmit distance.

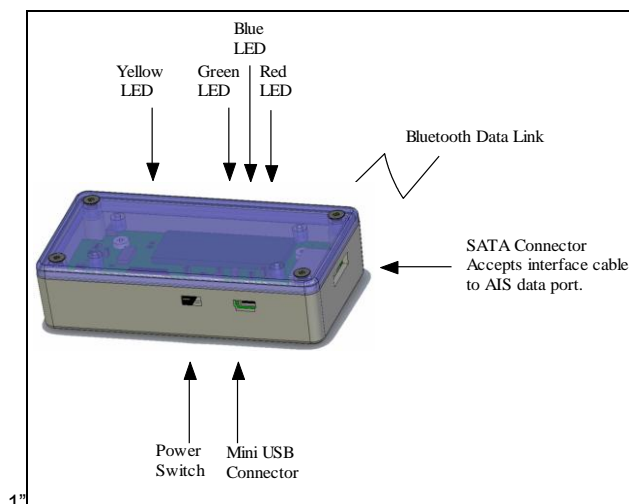

Figure 2 - Overview of the BPI

BPI Cables and Adapters

The Raven BPI kit contains the items pictured below.



The Raven BPI connects to the Ship's AIS PPI (Pilot Plug Interface) and provides AIS data to the laptop. The kit contains:

- 0.5-foot PP cable and a 5.5-foot PPI cable
- Loopback adapter attached to the shorter PPI cable. The loopback adapter lets the pilot verify that the Raven equipment is working.
- USB cable for charging the BPI and for hard-wire access to the AIS data.
- AC adapter for charging the BPI. You can plug the USB cable into a laptop or the AC adapter for charging.

BPI LED Status Lights

The BPI has 4 Light Emitting Diodes (LEDs) with the following meanings:

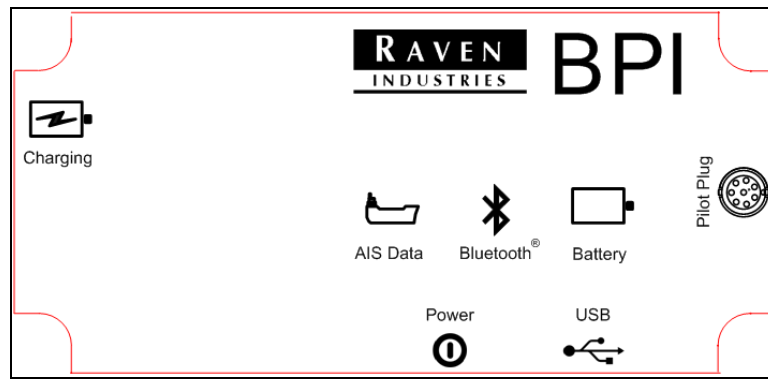

Figure 3 - Top view of BPI

Yellow LED - Charging

Solid battery is charging

Off battery is fully charged or external power via USB cable is not present

Green LED - AIS Data

Flash Codes ... 3 – receiving AIS data - Pilot Plug is incorrectly wired or has wrong baud rate

2 – BPI is in loopback mode

1 – BPI is searching for data on one of the various wire-pair combinations

Solid receiving AIS data from properly wired Pilot Plug Interface

Off BPI off or in standby

Notes:

- If no AIS data is received for 10 seconds the BPI will begin scanning
- See BPI message, 'Query PPI State', to determine details of incorrect wiring or wrong baud rate

Blue LED - Bluetooth

Flash Codes ... 3 – Initializing

2 – Waiting for pairing with host device

1 – Paired, but not connected

Solid paired and connected

Off BPI off or in standby

Notes:

- Users should wait for 2 blinks before attempting to pair to the BPI over the Bluetooth connection
- After cycling power on the BPI, the unit will go to 2 blinks, even if the device is paired. The attached computer will automatically restore the connection from 2 blinks.

Red LED - Battery

Flash Codes ... 2 – Battery communications error

1 – Battery charge is low

Solid battery charge has greater than 5 hours charge remaining

Off BPI is off or in standby

Ship's AIS and the Raven BPI

As part of the Coast Guard's Safety of Life at Sea (SOLAS) program, all commercial and passenger ships over a certain size or number of passengers are required to transmit their location and vessel information using a Coast Guard approved AIS (Automated Identification System) transponder. This information is received by all other vessels within radio distance by the ship's AIS receiver and converted into signals for local use.

Pilots can use this AIS information, in conjunction with special software, to show not only the location of the vessel they are on (known as the Local Vessel) but the location, size, course and speed of all remote SOLAS vessels.

The AIS signal is made available for ship pilots on a standardized 9 pin connector. The AIS standard defines all operating characteristics of the plug (known as a Pilot Plug Interface, or PPI) including size, location, voltage levels, pins and baud rates.

Many pilots have discovered, however, that often times the PPI has not been configured properly. Common installation errors include wrong baud rates, transmit and send lines swapped, and even missing wires. When this happens most off-the-shelf AIS and 422 signal converters will not work properly and pilots are left without critical AIS data.

The BPI solves wiring issues by scanning all possible combinations of wires and baud rates until it locates valid AIS messages. It then "locks" onto the AIS data stream and re-transmits the data over a standardized Bluetooth or USB serial data path.

Both the USB and Bluetooth ports will appear as standard RS232 serial ports on the remote machine. All BPI messages are handled on both the USB and Bluetooth ports. Raven recommends that the firmware should only be updated over the USB port, as is done by the Raven-supplied software utility, BpiTest.

USB Operation

Users must install drivers to use the USB port on the BPI. Drivers should either have been included with the BPI or are available from FTDI at <http://www.ftdichip.com/Drivers/VCP.htm>. Also, you can call Raven to find out how to get these drivers from the Raven FTP site.

To install the USB drivers:

- 1) Download the USB drivers, if necessary.
- 2) Power on the BPI and plug it into the remote machine.
- 3) Windows should recognize that a new device has been found and prompt you for the driver location.
- 4) Follow the steps on the "Found New Hardware" wizard to install the drivers for the BPI.
- 5) Once the driver has been installed, unplug the BPI from the USB connector, wait a few seconds then plug the device back in.
- 6) Windows should now recognize the BPI as a "Raven BPI" and install the correct drivers. The BPI should be ready to use.

To determine which serial port the BPI is using under Windows XP:

- 1) Install the drivers using the method above.
- 2) Open the Windows Device Manager by selecting Start -> Control Panel -> Administrative Tools -> Computer Management.
- 3) Select Device Manager in the left hand tree view.
- 4) In the right hand view, select "Ports (COM & LPT)".
- 5) Look for the port labeled "USB Serial Port". The serial port will be after this text (e.g. "USB Serial Port (COM58)").

Bluetooth Operation

To install the Bluetooth device, the user must install a Bluetooth adapter on the remote machine (many laptops have a built-in Bluetooth radio). They will also require Bluetooth manager software. Systems using Windows XP and later should have a default Bluetooth manager installed. Raven pre-installed systems do not use the default Windows XP Bluetooth Manager. Users of Raven systems should consult the Quick Start Guide for instructions on configuring the BPI to use the Bluetooth serial interface if their system has not already been pre-configured by Raven.

Bluetooth Performance

Bluetooth is a widely adopted wireless communication standard operating in the unregulated 2.4 gigahertz frequency range. This frequency range is used by many un-regulated wireless devices such as Wi-Fi, cordless phones, microwave ovens and portable radios, to name a few.

Bluetooth devices are categorized based on their maximum transmit power. In general, a device with higher transmit power will have a longer range. However, higher transmit power will also consume more power, thus decreasing battery life.

Class III devices have the lowest transmit power and thus the longest battery life. Class I devices have the highest transmit power and, thus, the lowest battery life. Class II devices will sit somewhere in the middle.

The BPI uses a Class I Bluetooth module with up to 4 milliwatts of transmit power. In order to maximize battery life, the BPI incorporates dynamic power management which will automatically lower transmit power to conserve battery life.

The BPI Bluetooth module is rated for greater than 100 meters of connection distance with no obstructions. Actual reliable transmit distance will be impacted, however, by the environment around the BPI, such as walls and other reflective surfaces as well as the presence of interference sources.

Note that for reliable operation both Bluetooth radios (BPI and remote host) must use a Class I Radio. Also note that the Bluetooth radios integrated in many laptops are Class II, which have a much shorter range than the BPI. If your laptop has a Class II Bluetooth radio, Raven recommends adding an after-market Class I Bluetooth adapter for best performance.

Bluetooth Connection

To configure a remote host to communicate with the BPI you must run a Bluetooth manager. Microsoft Windows XP and later version ship with a default Bluetooth manager. The following information is presented to help users understand the Bluetooth connection.

Users of Raven pre-installed systems can refer to the BPI Quick Start Guide for instructions on configuring the BPI for use over Bluetooth.

In general, setting up a Bluetooth connection is a 3 step process:

- 1) Power on the BPI and wait for the blue LED to enter a 2 blink mode, indicating it is ready for remote pairing.
- 2) Initiate a Bluetooth Device Scan on the remote device.
- 3) Select the BPI you wish to communicate with and configure the connection.

To ensure a secure Bluetooth connection, a remote host must discover certain information about the BPI. This process is known as “Pairing” and, once the BPI has been paired with a remote host the user will not have to enter any additional information to use the BPI over the Bluetooth connection (expect perhaps for entering the pass code, see below). In addition, the Bluetooth manager will assign a serial port unique to the BPI – this serial port will always be used when communicating with that particular BPI even if power is cycled many times.

The BPI Bluetooth connection exists in one of 3 states:

State	Blue LED	Description
Not Paired	2 Blinks	The BPI is either not associated with a remote device or the BPI power has been cycled since the last connection. Any remote user can attach to the BPI and begin communicating.
Paired	1Blink	The BPI has been communicating with the remote host, but the serial connection is not currently open. Only the remote host which was talking to the BPI can continue to do so.
Communication Open	Solid	The BPI is communicating with a remote host.

For additional security, the Bluetooth manager may require you to enter a security code known as a pass code. The default pass code for the BPI is “12345”. The pass code can be configured using the BTKEY command as outlined in the messages section.

The default Windows XP Bluetooth manager will require you to enter the pass code each time the connection is opened. This is not true of all Bluetooth managers, many of which will remember the entered pass code and transparently restore the connection when the port is opened by the software.

Once the Bluetooth connection has been setup, you can refer to the Bluetooth manager to determine which serial port the BPI is using on the remote machine.

Bluetooth Name

The scan results, as returned by your Bluetooth manager, will display both a MAC address and the name of the device.

The MAC address is a fixed number that uniquely identifies each Bluetooth device. The BPI has a label on the back of the unit showing the MAC address of your BPI. If the label falls off, you can also find the MAC address using a serial program and the DID message, or there is also an internal label on the Bluetooth antenna if you open the lid of the device.

The BPI also has what is known as a “Friendly” name that shows up on the Bluetooth scan. The default for the BPI is “Raven-BPI”. You can set this name using the NAME command (see messages section).

NOTE Windows allows users to “re-name” Bluetooth devices after the scan. Windows will remember any name you put in the manager but will NOT inform the BPI of this change.

If you rename the BPI after the scan using the NAME command to the BPI, the name will not change in the Bluetooth manager.

If you rename the BPI in the Bluetooth manager, this name will not be stored on the BPI.

Pilot Groups should contact Raven if they wish their default name to be changed.

AIS Operation

To connect the BPI to the Pilot Plug:

- 1) Connect either the 6-inch or 66-inch AIS cable to the BPI unit, depending on how far away the PPI is from the BPI.
- 2) Connect the AIS cable to the Pilot Plug.
- 3) Power on the BPI by sliding the On/Off switch away from the AIS connector.
- 4) The BPI will automatically begin scanning for signals and lock onto the correct pins.

A full scan of the plug takes about 15 seconds.

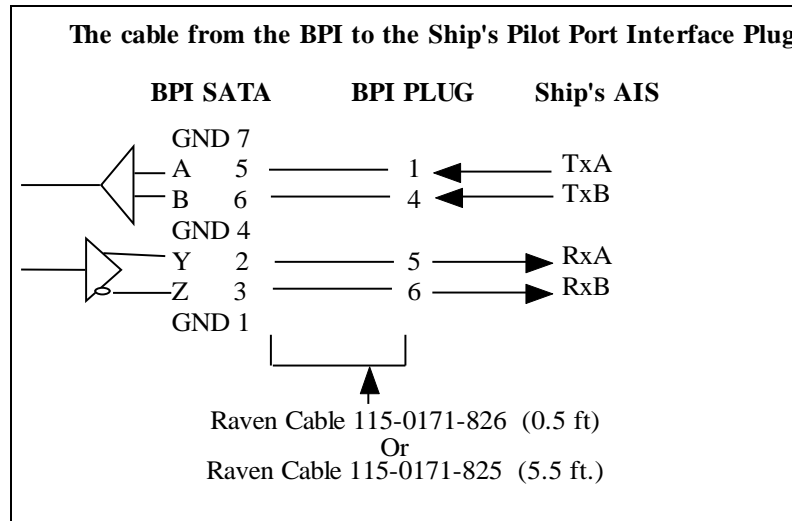

Figure 4 – BPI Cable Wiring Diagram

Soft Shutdown

Occasionally a user may neglect to power off the BPI and the battery will run dead before the next use. To prevent this, the BPI incorporates a soft shutdown feature which will turn off most internal hardware after a set period of time with no AIS data from the PPI.

When the BPI is in this state, no status lights will be illuminated and the battery uses a very small amount of current, about 3 times the current used when the unit is off.

To return to normal operation you must cycle the on/off switch.

The default time before shutdown is 60 minutes. This time can be changed with the STANDBY_MIN command message shown in the Command Messages section.

Low-Charge Shutdown

The BPI will automatically shut down when the charge declines to 2 or 3 percent. You must apply power to the BPI via the USB cable to get the BPI to turn back on. This behavior of the BPI prevents a deep discharge of the battery.

BPI Messages

BPI operation can be customized via a set of command messages. In addition to forwarding AIS data, the BPI will also report events of significance, such as scan state and battery status.

All commands are supported over any serial link - Bluetooth, USB, or AIS. Events are not reported on the AIS port.

Message Protocol

The messages use the Raven Starlink proprietary NMEA format and follow the NMEA sentence rules, including checksum, carriage return, and line feed ASCII control characters.

EXAMPLE: \$PSLIQ,BPI,NAME *cc

In the example

- \$PSLIQ represents a Starlink proprietary query message.
- BPI indicates the BPI device family.
- NAME indicates the type of query information desired.
- *cc indicates the checksum, per NMEA.
- There is an assumed carriage return, 0x0d, and line feed, 0x0a, after the checksum.

All configurable parameters are saved across power cycles in non-volatile EEPROM.

NOTE

The BPI will reject parameter changes silently if the battery is low and the BPI is not on the AC charger. This is to prevent corruption of the EEPROM that can occur if power is lost during an EEPROM write. When changing parameters Raven recommends users use the USB connection.

Command Messages and Related Query Messages

The BPI responds to each command with a response, as indicated below. Some command messages have corresponding Query messages and some do not.

Set BPI Name

Get or set the BPI friendly name which will be displayed as the result of a Bluetooth scan.

See the note under “Bluetooth Names” for more information on Bluetooth names.

\$PSLIS,BPI,NAME,friendlyName

\$PSLIQ,BPI,NAME

\$PSLIR,BPI,NAME,friendlyName

friendlyName	User-friendly device name for the BPI when making a Bluetooth connection from a PC. Default is “Raven-BPI”
--------------	---

Set BPI Bluetooth Security Key

Get or set the Bluetooth pass code.

The BPI will not set the Bluetooth security key until the power is cycled on the BPI.

\$PSLIS,BPI,BTKEY,key

\$PSLIQ,BPI,BTKEY

\$PSLIR,BPI,BTKEY,key

key	5-digit Bluetooth security key. Default is 12345. Pass code is limited to 8 digits.
-----	---

Set Event Messages On/Off

Turn event status messages on or off. See later section, Event Messages.

\$PSLIS,BPI,EVENT,eventState

\$PSLIQ,BPI,EVENT

\$PSLIR,BPI,EVENT,eventState

eventState	ON to enable event messages. OFF to disable event messages. Default is ON.
------------	--

Set Number of Minutes until Soft Shutdown

Get or set the amount of time without any AIS data before the BPI will shut down all internal hardware to conserve battery life.

See the “Soft Shutdown” section for more details on this feature.

\$PSLIS,BPI,STANDBY_MIN,minutesUntilShutdown
\$PSLIQ,BPI,STANDBY_MIN
\$PSLIR,BPI,STANDBY_MIN, minutesUntilShutdown

minutesUntilShutdown	<p>Number of minutes from the last received AIS message (or startup) before the BPI will shut itself off.</p> <p>A value of 0 disables this feature.</p> <p>Valid values are 10...300.</p> <p>Default is 60 minutes.</p>
----------------------	--

Reset Command

This command restarts the BPI system, but does not change any saved settings. There is no response message.

\$PSLIS,BPI,RESET

Factory Default Command

This command restarts the BPI system with the factory default configuration values. Any previously changed configuration values will be lost. Issuing this command will cause loss of the Bluetooth connection, if there is one. This command can be issued via the Bluetooth or USB link, but the USB link is preferable, since the USB link works regardless of the state of the Bluetooth link. After issuing this command via the USB link, you will have to close and reopen the USB device. There is no response message. You must cycle the power on the BPI after this command.

\$PSLIS,BPI,SETFACTORYDEFAULT

Loopback Mode

The loopback command places the BPI into a known state for utilizing the loopback test adapter attached to the Raven PPI cable. In this mode, messages sent over the USB and Bluetooth ports are transmitted out the AIS plug and the loopback adapter routes these messages back into the BPI. The BPI turns off event-reporting while in loopback mode.

\$PSLIS,BPI,LOOPBACK,state
\$PSLIR,BPI,LOOPBACK,state

state	<p>ON to force the BPI into LOOPBACK mode.</p> <p>OFF to return to normal scan operation. Default is OFF.</p>
-------	---

Force AIS Lock Mode

Force the BPI to lock onto the wire pairs and baud specified by the AIS standard.

Placing the BPI in this mode also disables the soft shutdown feature described earlier.

\$PSLIS,BPI,FORCE_AIS,state
\$PSLIR,BPI,FORCE_AIS,state

state	ON to force the BPI to lock onto the AIS wire pairs and Baud. OFF to return to normal scan operation. Default is OFF.
-------	--

Night mode for Status LED Lights

The status LED lights can be too bright at night. To dim them, send the following command with state = ON. To return to Day mode, let state = OFF.

This command has no effect on the charging (yellow) LED.

\$PSLIS,BPI,NIGHTMODE,state
\$PSLIQ,BPI,NIGHTMODE
\$PSLIR,BPI,NIGHTMODE,state

state	On to dim the blue, red and green LED indicators. OFF to return to day brightness. Default is OFF.
-------	---

Adjust Individual LED Brightness

The values for the day and night mode brightness (see Night mode for status LED lights, above) can be controlled using the following individual LED commands.

\$PSLIS,BPI,led,dayValue,nightValue

led	LED to set. One of: RED GREEN BLUE Yellow LED brightness cannot be set.
dayValue	PWM duty cycle for day Mode. Higher is brighter. Valid values are 10...254. Default is 220 for all LED status lights.
nightValue	PWM duty cycle for night Mode. Higher is brighter. Valid values are 10...254. Default is 20 for all LED status lights.

Event Messages

Event messages are sent unsolicited by the BPI. Event messages are on by default, but can be turned off by using the 'Set Event Messages On/Off' command described earlier in this document. Each of these messages have a corresponding query message as described later in the section, Stand-Alone Query Messages.

The following messages are events.

PPI State Response

The BPI sends this response automatically each 10 seconds. See the description of the PPI response message under section, Stand-Alone Query Messages -> Query PPI State.

Battery Parameters Response

The BPI sends this response automatically each 10 seconds. See the description the Battery response message under section, Stand-alone Query Messages -> Query Battery Parameters.

Performance Response

This event reports how efficiently the BPI is operating. The BPI sends this response automatically each 10 seconds.

\$PSLIR,BPI,PERF,[timeFor1000Loops],[SignalStrengInDbm],[BER],[422DeltaV]*cc

timeFor1000Loops	Time for the microprocessor to complete 1000 main loop iterations, in milliseconds.
SignalStrengInDbm	Bluetooth transmit power, in dbm. This value will only be valid if signal monitoring is on and the Bluetooth serial port is open.
BER	Bluetooth radio Bit Error Rate, in PPM. This value will only be valid if signal monitoring is on and the Bluetooth serial port is open.
422DeltaV	RS422 signal strength, in millivolts (valid locked) Only valid while the AIS signal is locked. Because the signal measurement is not synchronized with incoming data, this measurement may be 0 even with a valid connection.

Wire Wizard Scan Results

The BPI analyzes each of the 6 wire pairs for one second during a scan. When the BPI completes a scan of the AIS port it will report the results.

\$PSLIR,BPI,SCAN,signalOne,signalTwo,voltage,positiveSamples,negativeSamples,baudMask

signalOne	First signal wire. One of the BPI-defined input wires (TXA, TXB, etc)
signalTwo	Second signal wire. One of the BPI-defined input wires (TXA, TXB, etc)
voltage	Measured Peak-to-Peak voltage, in millivolts
positiveSamples	Number of measurements that had a positive voltage (signalTwo > signalOne).
negativeSamples	Number of measurements that had a negative voltage (signalTwo < signalOne). By comparing these two numbers you can get an idea of the numbers of marks (logical 1's) and spaces (logical 0's) on the data lines.
baudMask	A bitmask of possible baud rates for this pair. 0x01 – 9600 Baud found 0x02 – 19200 Baud found 0x04 – 38400 Baud found 0x08 – 9600 reversed Baud found 0x10 – 19200 reversed Baud found 0x20 – 38400 reversed Baud found .

Stand-Alone Query Messages

These messages do not have a corresponding command or 'Set' message and are query-only.

Query Battery Parameters

Query the state of the internal BPI battery. Reported battery results are based on an internal battery monitor. The internal battery monitor "learns" the battery under operation and can, especially when new, report inaccurate charge values.

This message is also sent as an event once every 10 seconds.

\$PSLIQ,BPI,BATTERY*cc

\$PSLIR,BPI,BATTERY,charge,voltage,averageCurrent,charging,minutesToEmpty,minutesToFull*cc

charge	Current estimated battery charge, as percentage from 0..100.
voltage	Battery output voltage, in Volts
averageCurrent	Average battery output current, in milliamps
charging	Battery reported Charging Status 1 = Charging 0 = Not Charging Note that this flag may not match the charging LED.
minutesToEmpty	Minutes to empty at current discharge rate. If the battery is charging, will report as 65535.
minutesToFull	Minutes to fully charge the battery at current charge rate. Reported as 65535 if the battery is not charging.

Important: If any of the variable fields above are unknown or invalid, then the value will be -1.

Query Device ID

\$PSLIQ,BPI,DID*cc

\$PSLIR,BPI,DID,modelName,fwver,fwChecksum,hwver,nnnnnnnnnn,btkey*cc

modelName	"Raven-BPI". The model name cannot be changed. The model name and the user-friendly name used in the set NAME message are initially the same, but the user-friendly name can be changed.
fwver	firmware version
fwChecksum	firmware checksum
hwver	hardware version
nnnnnnnnnn	12-digit MAC address of Bluetooth module This value may be "?????" for while the Bluetooth module is initializing.
btkey	Bluetooth security key

Query PPI State

Query the current status of the AIS connection.

This message is also sent as an event once every 10 seconds or during a scan whenever a line scan is completed.

\$PSLIQ,BPI,PPI

\$PSLIR,BPI,PPI,baud,rxa,rxb,state,lockState*cc

baud	Current Baud rate. One of 9600,19200,38400
rxa	Current Line attached to the RXA input of the BPI. See Signal Section for description of BPI lines.
rxb	Current Line attached to the RXB input of the BPI. See Signal Section for description of BPI lines.
state	Current search State. One of: Data Found Data Search
lockState	Current Lock State. One of: Wiring Error Wiring ??? Wiring Ok

Example: \$PSLIR,BPI,PPI,38400,AIS TXB,AIS TXA,Data Found,Wiring Ok*38

See section, AIS Operation, for a wiring diagram of the BPI interface to the Ship's AIS plug.

Diagnostic Messages

These messages are designed for isolating faults with the BPI and are not intended for general use.

Reset Battery Monitor

This command will clear all stored battery-monitor parameters. It is intended for use when the internal battery is replaced.

\$PSLIS,BPI,RESET_BATTERY

Reset Bluetooth Module

This command will reset the internal Bluetooth device to factory defaults. It is intended for use by Raven technical staff to help clear any Bluetooth connection issues.

\$PSLIS,BPI, RESET_BT

Bluetooth AT Command Mode

When in the AT Command mode, messages from the USB port are forwarded to the Bluetooth device and messages from the Bluetooth device are forwarded to the USB port. It is intended for debugging of the Bluetooth device.

\$PSLIS,BPI,ATCOMMAND,state
\$PSLIR,BPI,ATCOMMAND,state

state	ON to turn on ATCOMMAND mode Off to turn mode off.
-------	---

Begin a New Data Scan

\$PSLIS,BPI,BEGIN_SCAN

Force the BPI to begin an AIS data scan, regardless of lock status.

This event is used by Raven internally for diagnostic purposes related to searching for valid AIS data on the PPI port.

By default, the BPI automatically searches for data by trying different wire-pair combinations and baud rates. Baud rates are: 9600, 19200, and 38400.

Signal Interval

The BPI can dynamically measure the Bluetooth signal strength and Bit Error Rate (BER). However, to perform the necessary measurement, the Bluetooth data stream must be paused for an extended period which will result in dropped messages.

Raven does not recommend measuring signal strength during normal operation.

\$PSLIS,BPI,SIGINTERVAL,[secondsBetweenMeasurement]*cc
\$PSLIQ,BPI,SIGINTERVAL
\$PSLIR,BPI,SIGINTERVAL,[measInterval]

measInterval	Interval between signal strength and BER measurements, in seconds. 0 means this feature is off. The default is 0.
--------------	---

Update History

By Dale Gambill and Daniel Weber

- 06-30-2009/drw/dlg: Rev D, Added new messages and new sections.
- 03-23-2009/dlg: Rev C, Corrected date on title page. Replaced contact info with reference to contact info.
- 01-13-2009/dlg: Rev B, Added PERF and SIGINTERVAL messages; updated BPI photo on p. 4
- 08-29-2008/dlg: Rev A, First Release